

TWN 0001 TWIN SINGLE

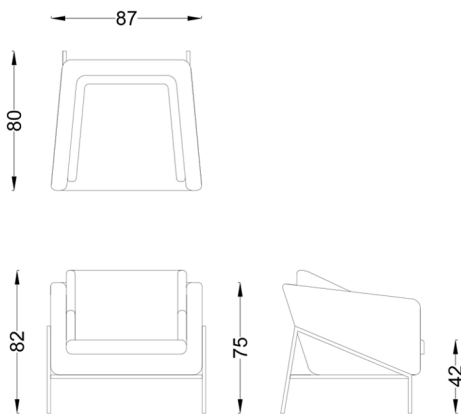

TWN 0002 TWIN DOUBLE

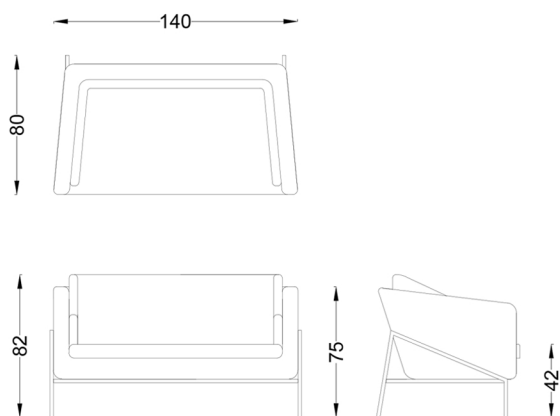

TWN 0003 TWIN TRIBLE

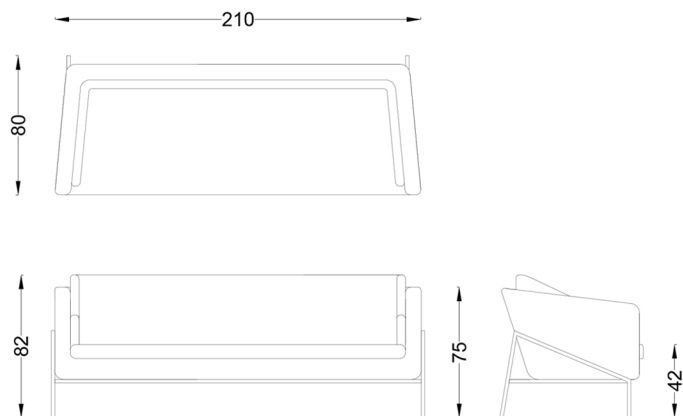

KOD / CODE	MODEL	U / L	D / D	Y / H	KG	M ³	LEATHER FABRIC M	GENUINE LEATHER M ²
TWN 0001	SINGLE	87	80	82	26,3	0,5	4,3	8,6
TWN 0002	DOUBLE	140	80	82	39,4	0,92	6	12
TWN 0003	TRIBLE	210	80	82	-	-	7,5	15

Framework : High dns polyurethane pouring in injection molds on a steel construction with an inside framework.

Sponge : Complete polyurethane injection molding. Seat is 8cm of 30dns sponges.

Leg : Static oven paint on 20mm*20mm*1.5mm pipe profile.

Fabric and faux leather alternatives are available.